

# MANUAL DE INSTRUCCIONES DE USO.

## *Modelo IP-VAP*

These instructions offer all the required information about the usage of IP-VA photovoltaic module family supplied by **PEVAFERSA**.

Instructions must be totally read through following the steps exposed.

The company shall not be liable for any damages, losses o expenses derived from the failure to comply the conditions specified below.

### **ELECTRICAL RISK.-**

Solar panels produce direct current. If one of them is exposed to the light of sun it may produce electric shock or burns. This risk increases when various modules are interconnected.

Other equipments that form the final group of a photovoltaic installation such as batteries, inverters and photovoltaic regulators can also mean risk.

- **ELECTRICAL RISK present in photovoltaic module installations.**



As already stated a module generates direct current, for this it is mandatory to handle with care (qualified personnel) in order to avoid possible **electric shocks**.

Always use suitable protection equipment (gloves, pole detection)



**Cover the modules with opaque material and stick with adhesive tape. This way voltage in the modules will be suppressed. Never eliminate voltage of the modules by short-circuit.**



 **Installation and future connection of modules must be done by a qualified electrician or under supervision of a authorized person.**

 The installation must take place under suitable weather conditions (avoid rain, snow...) in order to avoid **electric shocks**.

 Only use suitable tools to work on electrical installations, covered with **insulating material**.

- ❖ As values of the electrical characteristic have been calculated for standard measuring conditions according to **UNE- EN 61215** norm (1000W/m<sup>2</sup>, AM 1.5, 25°C), there may be the case that a **higher voltage** with respect to the stipulated can be produced. For this reason equipments such as regulators or cables must be prepared to support this possible increase. For limit temperature cases the limit value for the **correction factor** is **1,25**.

 All equipments, junction boxes, cable must be suitable for photovoltaic installations. **Never touch bare wires**. If cables are not to be connected immediately insulate them for protection. Never manipulate junction boxes extracting for instance the diodes placed by the manufacturer.



Modules must never be installed or manipulated near places where flammable gases are easily developed, **sparks** can be produced.



Never try modifying the electronic set up of the junction boxes. To avoid electric shock it is necessary to disconnect any electrical feed-in before installing and uninstalling connectors. Nevertheless the junction box already installed must be protected from electric shock.



Never try modifying direct or indirectly the electrical production by applying punctual luminous power sources.



**Keep children away from the photovoltaic modules.**

## **INSTRUCTIONS FOR A CORRECT INSTALLATION OF MODULES.-**

Our **IP-VAP** photovoltaic modules can be installed both for self-consumption and grid connection systems, in fixed installations or in solar tracking systems.

- **Location.**

- ✓ Important factors to be taken into account when locating a photovoltaic installation are **geographic latitud and season of the year**. Solar incidence is higher the nearer we are to the equator and consequently it decreases the closer we are to the poles. On the other hand the Earth varies its inclination with respect to the sun as it orbits around it depending on the season of the year in which we are. The panel must be orientated as much as possible towards the **South** (azimut=0°), so as to take the maximum advantage of the solar radiation.
- ✓ When installing the modules we must take care that they do not shade one another.
- ✓ There mustn't be nearby building, nor trees that interfere in the sun incidence on the modules.
- ✓ There must be a suitable air flow for the correct well functioning and to avoid condensation problems.
- ✓ The place of location must be of easy access for future actions.

- **Installation of modules on roofs.-**

They must be well fixed so they don't come loose even in maximum situations. Taking this into account we will use galvanized iron section to fix the panels. The fixing of the both section and panel will be done by elements (screws, nuts, washers) of a material resistant to time.

There must be a separation of more than 5,08mm ( 2") between the roof and the backside of the module so as to allow a air flow and avoid condensations.

- **Manipulation.**

You must pay special attention to the packaging, storage and posterior transportation, tying well the modules because the glass could fracture and the module would be totally useless.



- ✓ Do not dismantle the module in any case, nor extract any incorporated component.
- ✓ Do not walk on the module.
- ✓ If there is a series of panels interconnected and it is necessary to move around them, and if there is no other alternative, we will use the sections as point of support.

- ✓ The panel is a physical body that supports certain voltage, distortion, torsion...regulated by the competent norms but during installation and without acknowledge of these norms it is recommendable to take certain precautions. The panel must be transported being held from the longest sides to avoid non desirable torsion effects.



- ✓ Never bang the panel on any of its sides.

## • **Assembly and electrical installation.**

- ✓ Modules are classified at the production line depending on their power. They are already prepared to be connected in series or in parallel.
- ✓ For the assembly we will use a small crane or similar and we will start placing them from the top down. Previously we will place the structure as parallel to the ground as possible



There is risk of scrimmage or fall while installing the modules on the structure, for this reason workers must wear the necessary security systems such as harness, gloves or adequate footwear.



To avoid any type of risk while assembling the system, whether isolated or for grid connection, firstly the panel or the structure must be earth connected. We will use for this purpose one of the holes in the section, using a stew and a washer.

- ✓ The support structure must bear all possible mechanical loads (wind, snow...), calculated according to the region where located. Both structure and supports must be of a very resistant material such as stainless steel, galvanized iron or anodized aluminum.



- ✓ The photovoltaic modules will be fixed to the structure by preferably special antitheft silicon or with screws passed through the holes in the sections.

- ✓ Once all the modules have been placed they will be interconnected, positive with negative as shown in the figure below. (Connection in series).



- ✓ This type of connection is really simple due to its extensions of quick plugging.
- ✓ Junction boxes are fixed in the production line to the panel; they must be protected from scrimmage to keep inside connections in good conditions. We must also keep the sealing intact.
- ✓ Disposition of the connections allow us to modify panel exit voltages, this part will only be altered by the installer if previously authorized by the supplying company, becoming Pevafersa free of any responsibility if this is not done.

- ✓ Never change the protection diodes without previous authorization from the box manufacturer.

### ¿ Series or parallel assembly?

This will depend on the voltage required. If a high voltage is required we will connect the modules in series because final voltage will be

$$V = V_1 + V_2 + \dots + V_n \text{ and the intensity value } I = I_1 = I_2 = \dots = I_n$$

If on the other hand we are interested in obtaining high current intensities we will go for a connection in parallel:  $I = I_1 + I_2 + \dots + I_n$ .

$$V = V_1 = V_2 = \dots = V_n.$$

The maximum recommended configuration for modules connected in series is of a 1000V voltage. Isolation is guaranteed up to this voltage.

In a parallel connection you can connect as many modules as the gadget to which it is connected admits (ej. regulator or other suitable equipment)



Always use suitable cables for very high voltages can produce **short-circuit**, and high current intensities can **overheat** them.



A photovoltaic installation also has with it other additional equipments such as **inverters, regulator, batteries...** Recommendations of the manufacturers must be followed.

When intensity of short-circuit in the circuits connected to the Batteries is too high for the gadgets and protection elements to bear, we will install in each of the circuits short-circuit current limiting fuses to reduce the intensity of short-circuit. Fuses used are of **10 A**.

## **JUNCTION BOXES.-**

### ***PV-JB/S2-2-1AKE/N4SOL/095/3XSB1240***

Junction boxes incorporated to the backside of the panel are supplied by the company Multi-Contact, that also supply the connectors.

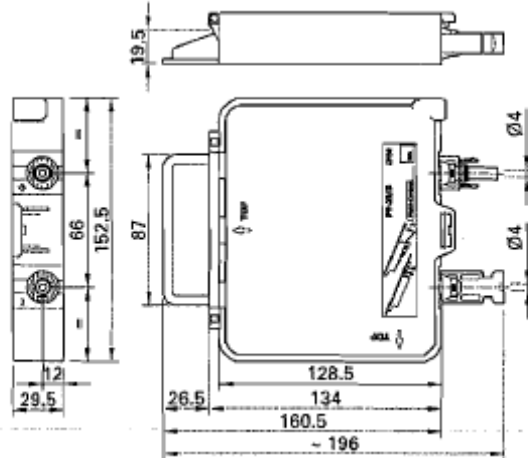

The junction boxes used offer an **IP-54** grade of protection. The first number indicates protection against solid elements (in this case dust). The second number indicates protection against liquid (in this case against jets of water).

This junction box, special for renewable energies, is easy to assemble. Diodes are already incorporated. The connections are introduced in the box easily using a tool.

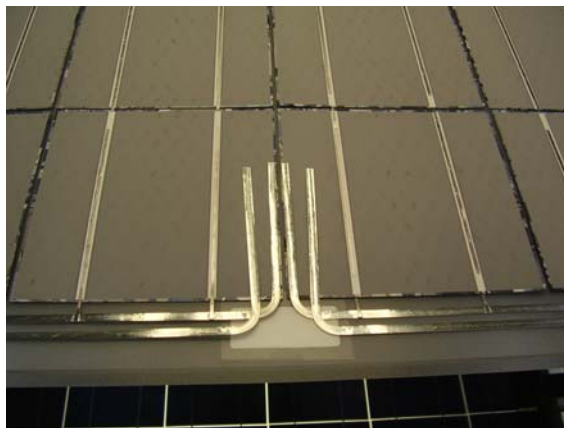

Tin connections in a photovoltaic panel.

To determine if a product is suitable or not you must contact the supplier of the product and send a sample of the material.

 When introducing the connections pay special attention to the correct polarity.

 All tools must be totally insulated to avoid electrical risk.

 Manipulation of the junction box must be done by a qualified person if the necessary knowledge in order not to alter any characteristic specified by the certification.

### ***CONNECTORS.-***

100 cm. long with a 4mm<sup>2</sup> section, more than enough to support the intensity generated by the panels. The characteristics are as follows:

- **Current intensity:** 20A
- **Max. System voltage:** 1000V
- **Temperature scale:** from -40 to 90 °C

For a connection in serie we will attach the positive connector to the negative connector of the following panel and so on.

 Use specific connectors for photovoltaic panels.

 Never disconnect nor connect while the circuit is loaded.

 Disconnected connectors should be protected from filth and water.

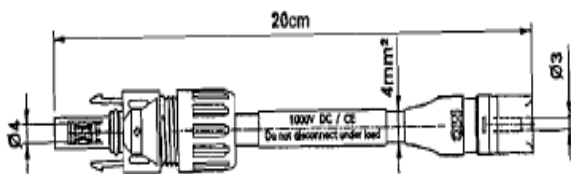

***PV-A-KBT4/KST3***

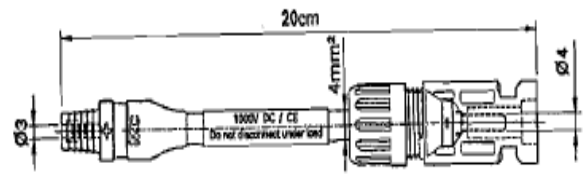

***PV-A-KBT3/KST34***



### ***DIODES.-***

In order to protect the module from any possible damage caused by partial shadows the protection box has 3 protection diodes by-pass type (Schottky) **12A** each. The use of these diodes Schottky, and not others, would offer a voltage drop at the exit of the smallest panel.



It prevents that each module individually may absorb current from other modules if in one or more modules are in a shade. **This way the loss of panel power is limited.**

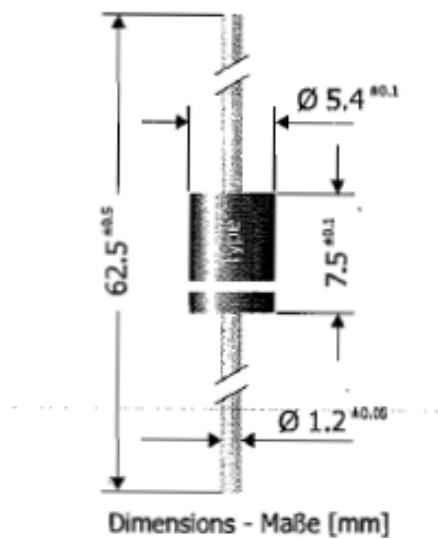

### Diode SB1240

As mentioned before, diodes are already incorporated in the junction boxes.



Never manipulate or change diode positions unless you are qualified and authorized personnel.

### ***FIXING OF THE JUNCTION BOX TO THE PHOTOVOLTAIC PANEL.-***

Surfaces to be put together must be not only clean but also dry and firm, free from separating agents.

If they are really dirty (grease, oil, waste...) , they must be cleaned with methanol or heptane applying the product with a cloth and for a maximum of 5 minutes.

For the fixing of the box to the panel use high-performance waterproof silicon glue that reticulates at room temperature. It is non corrosive and basically odorless. ***(DOW CORNING® 744)***



Disposition on the panel will be with cable exits downwards and to the left turning the box 90°.

## • MAINTENANCE.

Maintenance is minimum and simple:

- ✓ Checking system connections.
- ✓ Checking cable system especially if it has been in the sun or in bad weather conditions that can produce corrosion; cracks may appear on the covering which can produce energy loss.
- ✓ Checking the sealing of the boxes, even if there is a time lapse they should still be sealed and non corrosive due to water.
- ✓ Inspecting every so the pieces in the structure that supports the photovoltaic modules to check if any are loose.
- ✓ Checking if any glass may be fractured. If so contact the supplier and change the module.

- ✓ Mainly rain eliminates the necessity to clean de panels. If needed clean de surfaces with a mixture of neutral detergent and water.



Accumulation of waste (birds, industrial...) on the glass can reduce the output in a significant way.



Never clean the panel with pressurized water nor abrasives that can damage the panel.

## • MODULE BRANDING.

At the back of the panel you can find printed, and in a format as in the photo, the following paramenters.

- ✓ Electric parameters of the module (IP-VAP 200):

Power: 200W

Short circuit current: 7,74A

Voltage of open circuit: 36,80V

Intensity at max. power point: 7A

Voltage at max. power point: 28,58V

Nominal Operation temperatura of the cell (TONC): 47°C



✓ Other specifications.-



**¡ DANGER ! ELECTRICAL RISK.**

Read carefully the instructions. This module produces electricity when exposed to light (DC). Modules must never be installed or manipulated near places where flammable gases are easily developed. Do not try modifying electronic configuration of the junction boxes. Use tools covered with insulating materials. Never try modifying directly or indirectly the electrical production with punctual luminous energy sources. Eliminate voltage by covering the module with and opaque material. Never eliminate voltage by short-circuit. Keep modules away from children.

Safety *clase II*: **IEC 61140.**

Aplication class A <sup>(1)</sup>: IEC 61730-1

<sup>(1)</sup> IEC 61730-1 Clase A: Acceso general, voltajes peligrosos, aplicaciones de potencia peligrosas. Panels under this class can be used in systems operating above 50V in DC o 240W, where there is generally risk of contact. This type of application must comply with safety requirement in Class II.

***Any type of manipulation or installation that is not contained in the norms stipulated in this document and that means a doubt to the installer must be consulted with the company supplier to receive the correspondent information to the respect.***